



**Pearson
Edexcel**

Mark Scheme (Results)

Summer 2021

Pearson Edexcel International Advanced
Subsidiary/Advanced Level
In Decision Mathematics D1 (WDM11/01)

Edexcel and BTEC Qualifications

Edexcel and BTEC qualifications come from Pearson, the world's leading learning company. We provide a wide range of qualifications including academic, vocational, occupational and specific programmes for employers. For further information, please visit our website at www.edexcel.com.

Our website subject pages hold useful resources, support material and live feeds from our subject advisors giving you access to a portal of information. If you have any subject specific questions about this specification that require the help of a subject specialist, you may find our Ask The Expert email service helpful.

www.edexcel.com/contactus

Pearson: helping people progress, everywhere

Our aim is to help everyone progress in their lives through education. We believe in every kind of learning, for all kinds of people, wherever they are in the world. We've been involved in education for over 150 years, and by working across 70 countries, in 100 languages, we have built an international reputation for our commitment to high standards and raising achievement through innovation in education. Find out more about how we can help you and your students at: www.pearson.com/uk

Summer 2021

Question Paper Log Number P66639A

Publications Code WDM11_01_2106_MS

All the material in this publication is copyright

© Pearson Education Ltd 2021

General Marking Guidance

- All candidates must receive the same treatment. Examiners must mark the first candidate in exactly the same way as they mark the last.
- Mark schemes should be applied positively. Candidates must be rewarded for what they have shown they can do rather than penalised for omissions.
- Examiners should mark according to the mark scheme not according to their perception of where the grade boundaries may lie.
- There is no ceiling on achievement. All marks on the mark scheme should be used appropriately.
- All the marks on the mark scheme are designed to be awarded. Examiners should always award full marks if deserved, i.e. if the answer matches the mark scheme. Examiners should also be prepared to award zero marks if the candidate's response is not worthy of credit according to the mark scheme.
- Where some judgement is required, mark schemes will provide the principles by which marks will be awarded and exemplification may be limited.
- Crossed out work should be marked UNLESS the candidate has replaced it with an alternative response.

EDEXCEL IAL MATHEMATICS

General Instructions for Marking

1. The total number of marks for the paper is 75.
2. The Edexcel Mathematics mark schemes use the following types of marks:
 - **M** marks: method marks are awarded for 'knowing a method and attempting to apply it', unless otherwise indicated.
 - **A** marks: Accuracy marks can only be awarded if the relevant method (M) marks have been earned.
 - **B** marks are unconditional accuracy marks (independent of M marks)
 - Marks should not be subdivided.
3. Abbreviations

These are some of the traditional marking abbreviations that will appear in the mark schemes.

- bod – benefit of doubt
 - ft – follow through
 - the symbol \checkmark will be used for correct ft
 - cao – correct answer only
 - cso - correct solution only. There must be no errors in this part of the question to obtain this mark
 - isw – ignore subsequent working
 - awrt – answers which round to
 - SC: special case
 - oe – or equivalent (and appropriate)
 - dep – dependent
 - indep – independent
 - dp decimal places
 - sf significant figures
 - * The answer is printed on the paper
 - \square The second mark is dependent on gaining the first mark
4. All A marks are 'correct answer only' (cao.), unless shown, for example, as A1 ft to indicate that previous wrong working is to be followed through. After a misread however, the subsequent A marks affected are treated as A ft, but manifestly absurd answers should never be awarded A marks.
 5. For misreading which does not alter the character of a question or materially simplify it, deduct two from any A or B marks gained, in that part of the question affected.
 6. If a candidate makes more than one attempt at any question:
 - If all but one attempt is crossed out, mark the attempt which is NOT crossed out.

- If either all attempts are crossed out or none are crossed out, mark all the attempts and score the highest single attempt.
7. Ignore wrong working or incorrect statements following a correct answer.

Question Number	Scheme	Marks																																																																																																
1. (a)	$\frac{177}{45} = 3.933\dots$ so lower bound is 4	M1 A1 (2)																																																																																																
(b)	Container 1: 16 23 4 Container 2: 18 9 <u>5</u> 13 Container 3: <u>20</u> 17 6 Container 4: <u>35</u> Container 5: 11	M1 <u>A1</u> A1 (3)																																																																																																
(c)	<table border="1"> <tbody> <tr><td>16</td><td>23</td><td>18</td><td>9</td><td>4</td><td>20</td><td>35</td><td>5</td><td>17</td><td>13</td><td>6</td><td>11</td></tr> <tr><td>23</td><td>18</td><td>16</td><td>9</td><td>20</td><td>35</td><td>5</td><td>17</td><td>13</td><td>6</td><td>11</td><td>4</td></tr> <tr><td>23</td><td>18</td><td>16</td><td>20</td><td>35</td><td>9</td><td>17</td><td>13</td><td>6</td><td>11</td><td>5</td><td>4</td></tr> <tr><td>23</td><td>18</td><td>20</td><td>35</td><td>16</td><td>17</td><td>13</td><td>9</td><td>11</td><td>6</td><td>5</td><td>4</td></tr> <tr><td>23</td><td>20</td><td>35</td><td>18</td><td>17</td><td>16</td><td>13</td><td>11</td><td>9</td><td>6</td><td>5</td><td>4</td></tr> <tr><td>23</td><td>35</td><td>20</td><td>18</td><td>17</td><td>16</td><td>13</td><td>11</td><td>9</td><td>6</td><td>5</td><td>4</td></tr> <tr><td>35</td><td>23</td><td>20</td><td>18</td><td>17</td><td>16</td><td>13</td><td>11</td><td>9</td><td>6</td><td>5</td><td>4</td></tr> <tr><td>35</td><td>23</td><td>20</td><td>18</td><td>17</td><td>16</td><td>13</td><td>11</td><td>9</td><td>6</td><td>5</td><td>4</td></tr> </tbody> </table>	16	23	18	9	4	20	35	5	17	13	6	11	23	18	16	9	20	35	5	17	13	6	11	4	23	18	16	20	35	9	17	13	6	11	5	4	23	18	20	35	16	17	13	9	11	6	5	4	23	20	35	18	17	16	13	11	9	6	5	4	23	35	20	18	17	16	13	11	9	6	5	4	35	23	20	18	17	16	13	11	9	6	5	4	35	23	20	18	17	16	13	11	9	6	5	4	M1 A1 A1ft A1cso (4)
16	23	18	9	4	20	35	5	17	13	6	11																																																																																							
23	18	16	9	20	35	5	17	13	6	11	4																																																																																							
23	18	16	20	35	9	17	13	6	11	5	4																																																																																							
23	18	20	35	16	17	13	9	11	6	5	4																																																																																							
23	20	35	18	17	16	13	11	9	6	5	4																																																																																							
23	35	20	18	17	16	13	11	9	6	5	4																																																																																							
35	23	20	18	17	16	13	11	9	6	5	4																																																																																							
35	23	20	18	17	16	13	11	9	6	5	4																																																																																							
(d)	Container 1: 35 <u>9</u> Container 2: 23 20 Container 3: 18 17 6 4 Container 4: 16 <u>13</u> <u>11</u> 5	M1 <u>A1</u> A1 (3)																																																																																																
		12 marks																																																																																																

Notes for Question 1

a1M1: Attempt to find the lower bound $(177 \pm 35) / 45$. A value of 3.9 or better (for example, 3.93, 3.933, 3.9333..., $\frac{59}{15}$, etc.) seen with no corresponding calculation can imply this mark. Allow this mark for a clear intention of adding **all twelve** values and dividing by 45, for example,

$$\frac{16 + 23 + 18 + 9 + 4 + 20 + 35 + 5 + 17 + 13 + 6 + 11}{45}$$
 scores M1

a1A1: CAO (correct answer only) - correct calculation seen followed by 4 **or** the correct value of 3.9 or better stated (see note above for mark **a1M1**) followed by 4. However, an answer of 4 with no working scores no marks in this part

b1M1: First five items placed correctly and at least eight values placed in containers. The first five values are those in bold. Condone cumulative totals for M1 only (e.g. for Crate 1: 16 39 43)

b1A1: First eight items placed correctly (the underlined **and** bold values). This mark cannot be awarded if you see **any** repeated values or more than twelve items placed in crates (even if the first eight items have been placed correctly)

b2A1: CSO (correct solution only). No additional or repeated values

c1M1: Bubble sort. Consistent direction, end number (4) in place and the list beginning with the correct first four numbers (23 18 16 9). Do check these carefully as some candidates show the result of each comparison and swap in their first pass. Consider the placement of the candidate's numbers, rather than what the candidate labels each line of their pass. For example, assume that the first time that the 4 appears at the end of the list is the end of their first pass

c1A1: The first, second **and** third passes correct – so end three numbers in place

Question Number	Scheme	Marks
-----------------	--------	-------

c2A1ft: Fourth and fifth passes correct following through from the candidate's third pass – so end five numbers in place

c3A1: CSO (correct solution only – so previous three marks must have been awarded in this part). Must show a 7th pass showing no swaps/changes. Condone if the sort continues until an 11th pass has been completed (but there should be no changes in the 8th to 11th passes) **or** if the pass stops between an 8th and 11th pass (provided there are no changes in the values in any pass after the 6th pass)

d1M1: Must be using correct sorted list in descending order (so no follow through or misreads from an incorrect list from (c)). First six items placed correctly and at least eight values placed in containers. Note that the first six items are the bold values. Condone cumulative totals for M1 only. First-fit increasing scores no marks in this part

d1A1: First nine items placed correctly (the underlined and bold values). No additional or repeated values

d2A1: CSO. So no additional or repeated values

Sorting into ascending order in (c)

- If the candidate sorts the list into ascending order and reverses the list they can score full marks
- If the list is not reversed in (c) then mark as a misread (so mark according to the main scheme and then subtract the final two A marks earned). If the candidate says that the list needs reversing but doesn't actually show the reversed list then remove the final A mark earned

Misreads for part (c) only – if there is a 'misread' of a single number (this could take the form of an extra number, a number missing, or a number changed, for example, 42 rather than 23) before starting the sort in (c) then mark as a misread. If they 'misread' more than one number then M0. If they miscopy one of their own numbers during the sort then this is an accuracy error and loses the corresponding A mark(s) according to the scheme. No misreads permitted in (a), (b) and (d) (so mark to the main scheme)

For reference the sort in ascending order is:

16	23	18	9	4	20	35	5	17	13	6	11
16	18	9	4	20	23	5	17	13	6	11	35
16	9	4	18	20	5	17	13	6	11	23	35
9	4	16	18	5	17	13	6	11	20	23	35
4	9	16	5	17	13	6	11	18	20	23	35
4	9	5	16	13	6	11	17	18	20	23	35
4	5	9	13	6	11	16	17	18	20	23	35
4	5	9	6	11	13	16	17	18	20	23	35
4	5	6	9	11	13	16	17	18	20	23	35
4	5	6	9	11	13	16	17	18	20	23	35

Question Number	Scheme	Marks
2.(a)		<p>M1</p> <p>A1</p> <p>M1</p> <p>A1 (4)</p>
(b)	<p>e.g.</p>	<p>M1</p> <p>A1</p> <p>A1</p> <p>A1 (4)</p>
(c)	<p>Lower bound is 4 workers e.g. activities K, M, N and Q together with $20 < \text{time} < 21$</p>	<p>M1 A1 (2)</p>
		<p>10 marks</p>

Question Number	Scheme	Marks
Notes for Question 2		
<p>a1M1: All top boxes complete (condone lack of 0 for the M mark only), values generally increasing in the direction of the arrows (so generally going from ‘left to right’ across the network), condone one ‘rogue’ value (if values do not increase in the direction of the arrows then if one value is ignored and the remaining values do increase in the direction of the arrows then this is considered to be a single rogue value). Note that all values in the top boxes could be incorrect but it can still score the M mark if the values are increasing in the way stated above</p>		
<p>a1A1: CAO – all values correct in the top boxes</p>		
<p>a2M1: All bottom boxes complete (but condone a blank box for the late event time at the end of activities P/Q and/or at the start node for this method mark only). Values generally decreasing in the opposite direction of the arrows (so generally going from ‘right to left’ across the network), condone one ‘rogue’ (as described above in a1M1)</p>		
<p>a2A1: CAO – all values correct in the bottom boxes</p>		
<p>Note that in (b) it is acceptable for the critical activities (C, E, G, J, N and P) to appear on separate lines or for several activities to appear on the same line as long as their durations and total floats are clear and do not overlap. The floats on the non-critical activities do not need to be shaded but they must be clearly distinguishable from the duration of the activity</p>		
<p>b1M1: At least ten different activities labelled including at least six floats. A scheduling diagram (so a diagram in which no floats are evident) scores M0</p>		
<p>b1A1: The critical activities dealt with correctly and appearing just once (C, E, G, J, N and P) and three non-critical activities dealt with correctly (both duration and total float correct)</p>		
<p>b2A1: Any six non-critical activities correct (this mark is not dependent on the previous A mark)</p>		
<p>b3A1: CSO – completely correct Gantt chart (exactly sixteen activities appearing just once)</p>		
<p>c1M1: Either a statement with the correct number of workers (4) and stating the correct activities (K, M, N and Q) with any numerical time stated or the correct number of workers (4) and a time in the interval $20 \leq x \leq 21$ – mark the numerical value only not their use of the words ‘day/time’ (or equivalent)</p>		
<p>c1A1: A completely correct statement with details of both time and activities. Candidates must give a time within the correct interval of $20 < t < 21$, e.g. 20.5 and state the correct activities (K, M, N and Q). Please note the strict inequalities for the time interval (e.g. implying a time of 20 is incorrect). Answers given as an interval of time are acceptable provided the time interval stated is correct for all its possible values (e.g. time 20 – 21 is A0). A completely correct statement with an additional incorrect statement scores A0 (so do not ignore subsequent working)</p>		

Question Number	Scheme	Marks																					
3.(a)	<table border="1"> <thead> <tr> <th>a</th> <th>b</th> <th>Qn</th> </tr> </thead> <tbody> <tr> <td>1</td> <td>0.967168(21)</td> <td>N</td> </tr> <tr> <td>0.967168(21)</td> <td>0.972789(34)</td> <td>N</td> </tr> <tr> <td>0.972789(34)</td> <td>0.971833(85)</td> <td>N</td> </tr> <tr> <td>0.971833(85)</td> <td>0.971996(47)</td> <td>N</td> </tr> <tr> <td>0.971996(47)</td> <td>0.971968(80)</td> <td>N</td> </tr> <tr> <td>0.971968(80)</td> <td>0.971973(50)</td> <td>Y</td> </tr> </tbody> </table>	a	b	Qn	1	0.967168(21)	N	0.967168(21)	0.972789(34)	N	0.972789(34)	0.971833(85)	N	0.971833(85)	0.971996(47)	N	0.971996(47)	0.971968(80)	N	0.971968(80)	0.971973(50)	Y	M1
	a	b	Qn																				
	1	0.967168(21)	N																				
	0.967168(21)	0.972789(34)	N																				
	0.972789(34)	0.971833(85)	N																				
	0.971833(85)	0.971996(47)	N																				
	0.971996(47)	0.971968(80)	N																				
0.971968(80)	0.971973(50)	Y																					
Final output is 0.97197	A1	(4)																					
(b)	Consideration of $12 - 5a$ being negative (oe)	M1																					
	$a > 2.4$	A1 (2)																					
		6 marks																					

Notes for Question 3

Candidates may write each value for a , b and N/Y (or No/Yes) in a new row which is fine. Assume that each row begins and ends when a value is changed. For example, the values in row 2 in the table above consists of the a value of 0.967168 and the b value of 0.972789. In (a) for the first three marks the values for a and b must be given to at least 6 decimal places (but accepted either rounded or truncated values)

a1M1: At least **three** rows of cells for columns a and b completed with a correct first row (so 1 for a and 0.967168 for b)

a1A1: CAO for the first three rows (for just the a and b columns) – to at least 6 dp

a2A1: CAO for the fourth and fifth rows (for just the a and b columns) – to at least 6 dp

a3A1: CSO - Output **must** be correct and written in the 'Final Output' box at the bottom of the page. This value must be given as 0.97197 (do not accept any other value). Candidates **must** have completed the third column of the table correctly to score this mark

b1M1: Consideration that the fourth root cannot be negative – allow just stating the critical value of 2.4 for this mark or stating or implying one of $f(a) \leq 0$ or $f(a) = 0$ or $f(a) < 0$ where

$$f(a) = 12 - 5a \text{ or } f(a) = \frac{12 - 5a}{8} \text{ or } f(a) = (12 - 5a)^{\frac{1}{4}} \text{ or } f(a) = \left(\frac{12 - 5a}{8}\right)^{\frac{1}{4}}$$

Allow any letter for a (e.g. x)

b1A1: CAO (must be a strict inequality and must be using a)

Question Number	Scheme	Marks																																																																
4. (a)	<table border="1"> <thead> <tr> <th></th> <th>A</th> <th>B</th> <th>C</th> <th>D</th> <th>E</th> <th>F</th> <th>G</th> </tr> </thead> <tbody> <tr> <th>A</th> <td>-</td> <td>21</td> <td>42</td> <td>17</td> <td>25</td> <td>31</td> <td>41</td> </tr> <tr> <th>B</th> <td>21</td> <td>-</td> <td>26</td> <td>27</td> <td>12</td> <td>15</td> <td>20</td> </tr> <tr> <th>C</th> <td>42</td> <td>26</td> <td>-</td> <td>32</td> <td>17</td> <td>11</td> <td>46</td> </tr> <tr> <th>D</th> <td>17</td> <td>27</td> <td>32</td> <td>-</td> <td>15</td> <td>21</td> <td>47</td> </tr> <tr> <th>E</th> <td>25</td> <td>12</td> <td>17</td> <td>15</td> <td>-</td> <td>6</td> <td>32</td> </tr> <tr> <th>F</th> <td>31</td> <td>15</td> <td>11</td> <td>21</td> <td>6</td> <td>-</td> <td>35</td> </tr> <tr> <th>G</th> <td>41</td> <td>20</td> <td>46</td> <td>47</td> <td>32</td> <td>35</td> <td>-</td> </tr> </tbody> </table>		A	B	C	D	E	F	G	A	-	21	42	17	25	31	41	B	21	-	26	27	12	15	20	C	42	26	-	32	17	11	46	D	17	27	32	-	15	21	47	E	25	12	17	15	-	6	32	F	31	15	11	21	6	-	35	G	41	20	46	47	32	35	-	B2, 1, 0 (2)
		A	B	C	D	E	F	G																																																										
	A	-	21	42	17	25	31	41																																																										
	B	21	-	26	27	12	15	20																																																										
	C	42	26	-	32	17	11	46																																																										
	D	17	27	32	-	15	21	47																																																										
	E	25	12	17	15	-	6	32																																																										
	F	31	15	11	21	6	-	35																																																										
G	41	20	46	47	32	35	-																																																											
(b)	NNA starting at A: A – D – E – F – C – B – G – A $17 + 15 + 6 + 11 + 26 + 20 + 41 = 136$ (km)	M1 A1 (2)																																																																
(c)	A – D – E – F – C – F – B – G – B – A	B1 (1)																																																																
(d)	RMST weight = $12 + 6 + 11 + 15 + 20 = 64$	B1																																																																
	$64 + 17$ (AD) + 21 (AB) = 102 (km)	M1 A1 (3)																																																																
(e)	AC + EG = $42 + 32 = 74$	M1																																																																
	AE + CG = $25 + 46 = 71$	A1																																																																
	AG + CE = $41 + 17 = 58^*$	A1																																																																
	Repeat arcs: AB, BG, CF, EF	A1																																																																
	Length: $291 + 58 = 349$ (km)	A1ft (5)																																																																
		13 marks																																																																

Notes for Question 4

Condone lack of, or incorrect units throughout this question

a1B1: At least two of the six values correct (in either table) – these are the bold values. The two values can be the same (for example, 42 in both cells AC and CA would score this mark)

a2B1: Fully correct (the six bold values in both tables)

b1M1: Nearest neighbour route starting at A – must have at least A – D – E – F – C – B – ...

Allow if stated in terms of arcs (AD, DE, EF, FC, CB,...) rather than nodes (note that arcs AD and DA are equivalent and so therefore AD, ED, EF, FC, CB,... is acceptable)

b1A1: CAO on length (136) **and** route (must return to A and can be stated in terms of arcs rather than nodes)

c1B1: CAO (ADEFCEFBGGBA or in terms of arcs, e.g., AD, DE, EF, FC, CF, FB, BG, GB, BA)

d1B1: CAO on the weight of the RMST (using arcs BE, EF, CF, DE, BG) – accept either 64 **or** $12 + 6 + 11 + 15 + 20$ – could be seen or implied by later working as part of the lower bound calculation

d1M1: Adding correct two least weighted arcs from A (17 (AD) + 21 (AB)) to their RMST length where their RMST length x is $58 \leq x \leq 70$

d1A1: CAO (102). If this answer is stated with no working then award B0M1A1

e1M1: Correct three distinct pairings of the correct four odd nodes (A, C, E and G)

e1A1: Any two rows correct including pairings **and** totals

e2A1: All three rows correct including pairings **and** totals

e3A1: CAO correct edges clearly stated and not just in their working as AB, BG, CF and EF – must be these arcs. Do not accept AG, ABG or AG via B (and similarly for CE)

e4A1ft: Follow through their value of their smallest pairing total + 291

Question Number	Scheme	Marks
5.(a)	Start at A e.g. we would be able to find the shortest distance from A to every other vertex e.g. A appears in both required routes	B1 B1dep (2)
(b)	<p>Shortest path to J: A C D G F J Length: 80 (miles) Shortest path to K: A C D B E H K Length: 81 (miles)</p>	M1 A1 (ACDBG) A1 (EFH) A1ft (JK) A1 A1 A1ft (7)
(c)	Route from F to H via A: F G D C A C D B E H	B1 (1)
Notes for Question 5		10 marks

a1B1: CAO (A) – if more than (vertex) A stated then B0

a2B1dep: Correct reason for starting at A (dependent on first B mark) – either need to explicitly mention that A appears on both routes **or** if starting at A then the shortest route to all other vertices (or just to vertices J and K) can be found

In (b) it is important that all values at each node are checked very carefully – the order of the working values must be correct for the corresponding A mark to be awarded e.g. at F the working values must be 51 49 48 in that order (so 51 48 49 is incorrect)

It is also important that the order of labelling is checked carefully. The order of labelling must be a strictly increasing sequence – so 1, 2, 3, 3, 4, ... will be penalised once (see notes below) but 1, 2, 3, 5, 6, ... is fine. Errors in the final values and working values are penalised before errors in the order of labelling

b1M1: Any larger working value replaced by any smaller working value at any two nodes except A and C (for example, if correct at B, 32 is replaced by 31 which is a larger value being replaced by a smaller value at one node – as this is a method mark the values do not need to be correct)

b1A1: All values at A, C, D, B and G correct and the working values in the correct order (including order of labelling so nodes must be labelled in the order A, then C, then D, then B, then G). Condone lack of a zero as a working value at A

b2A1: All values at E, F and H correct and the working values in the correct order. Penalise order of labelling only once per question (so E, F and H must be labelled in that order and E must be labelled after A, C, D, B and G)

b3A1ft: All values in J and K correct on the follow through and the working values in the correct order. Penalise order of labelling only once per question. To follow through J check that the working values at J follow from the candidate's final values for the nodes that are directly attached to J (which are A, F and G). For example, if correct then the order of labelling of nodes A, F and G is 1, 7 and 5 respectively so the working values at J should come from A, G and F in that order. The first working value at J should be 0 (the Final value at A) + 84 (the weight of the arc AJ), the second working value at J should be 40 (the Final value at G) + 42 (the weight of the arc GJ) and the final working value at J should be 48 (the Final value at F) + 32 (the weight of the arc FJ). Repeat the process for K (which will have working values from D, G and H with the order of these nodes determined by the candidate's order of labelling at D, G and H)

b4A1: One correct route (either ACDGFJ or ACDBEHK) – allow if reversed (e.g. JFGDCA) and allow if stated in terms of arcs (e.g. AC, CD, DG, GF, FJ)

b5A1: Both routes correct (as for **b4A1** – routes can be reversed and accept in terms of arcs)

b6A1ft: Both lengths correct following through **their** Final values at J and K. Condone correct answers or correct answers following through their diagram even if not explicitly clear which value refers to which path

c1B1: Correct answer only (FGDCACDBEH or FG, GD, DC, CA, AC, CD, DB, BE, EH) – if stated in terms of arcs then arcs AC and CD must appear twice in their route

If Dijkstra is completed twice (from J **and** K) then full marks can be awarded. If the candidate uses **just** J or K as the starting vertex in **(b)** then this is not a misread. The candidate can score if starting at J: M1 (as above), A1 (for correct values at J, F, G, B, D), A0, A0, A1 (for route JFGDCA), A1 (for length 80), A0 so 4 out of 7 max.

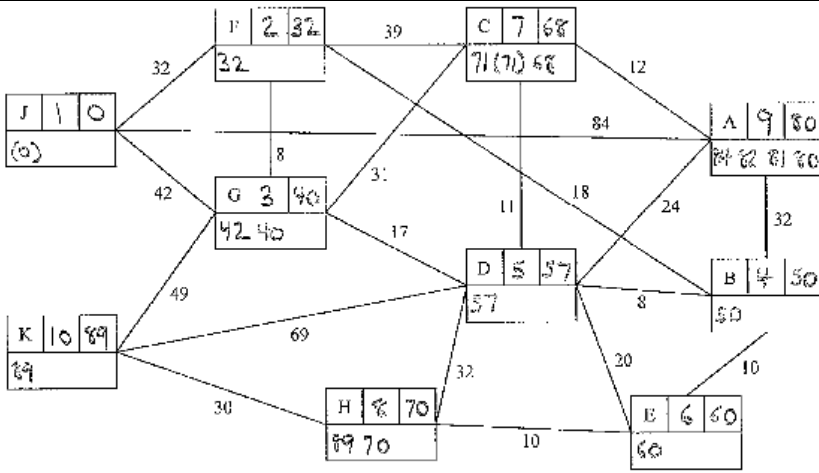

If starting at K: M1 (as above), A1 (for correct values at K, H, E, G, B), A0, A0, A1 (for route KHEBDCA), A1 (for length 81), A0 so 4 out of 7 max.

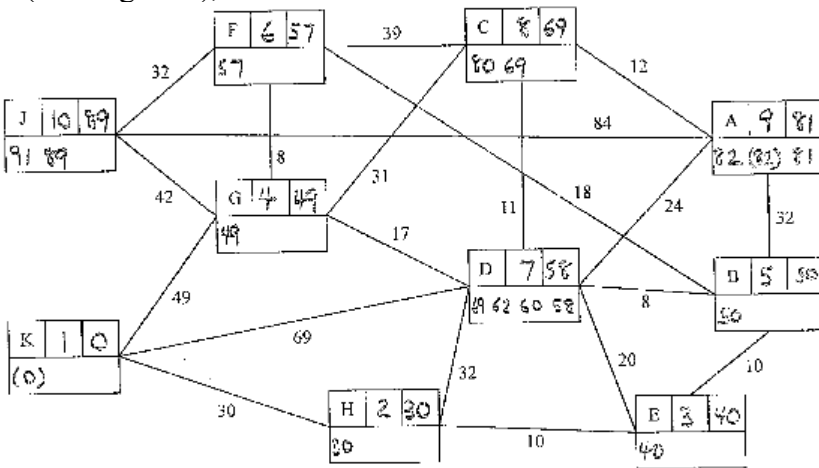

Question Number	Scheme	Marks
6.(a)	<p>e.g.</p>	<p>M1 A1 A1 A1 A1 (5)</p>

(b)	Activity I is guaranteed to be critical...	M1
	...because all paths (from source to sink) contain activity I	A1 (2)
(c)	Minimum project completion time is 12 (hours)	B1
	Critical path is C G H I L M	B1 (2)
		9 marks

Notes for Question 6

In (a) condone lack of, or incorrect, numbered events throughout. 'Dealt with correctly' means that the activity starts from the correct event but need not necessarily finish at the correct event. For example, 'I dealt with correctly' requires the correct precedences for this activity, i.e. D, E, F and H labelled correctly **and** that they lead directly into the same node (possibly with the aid of a dummy activity). Activity I then starts from that node but ignore the end event for I. The table below is useful in checking this. **Activity on node is M0**

Activity	A	B	C	D	E	F	G	H	I	J	K	L	M
IPA	-	-	-	A	A	A, B, C	C	G	D, E, F, H	I	I	I	L

If an arc is not labelled, for example, if the arc for activity E is not labelled (but the arc is present) then this will lose the first A mark and the final (correct solution only) A mark – they can still earn the second A mark on the bod (benefit of doubt). If two or more arcs are not labelled then mark according to the scheme. Assume that a solid line which has not been labelled is an activity rather than a dummy (even if in the correct place for where a dummy should be)

Ignore incorrect or lack of arrows on the activities for the first four marks only

a1M1: Eight activities (labelled on arc), one start and at least two dummies placed

a1A1: Activities A, B, C, 1st two dummies, D, E and G dealt with correctly. The first two dummies are those at the end of activities A and C. Both dummies must have arrows pointing in the correct direction

a2A1: Activities F, H and 3rd dummy dealt with correctly. The 3rd dummy is the one at the end of D. The dummy must have an arrow pointing in the correct direction

a3A1: Activities I, J, K, L and M dealt with correctly

a4A1: CSO – all arrows correctly placed for each activity with one finish and a 4th dummy (with a correct arrow) at the end of activity J. **Please check all arcs carefully for arrows – if there are no arrows on any dummies then M1 only. Note that additional (but unnecessary) 'correct' dummies that still maintain precedence for the network should only be penalised with the final A mark, if earned, in (a)**

Note additional valid solutions:

- Activities D and E interchanged **or** J and K interchanged (or both)
- The dummy at the end of D could appear before activity D, similarly for the dummy at the end of J
- A combination of both these points, e.g. D and E interchanged and the corresponding dummy appearing before the activities
- The arrow on the 'final' dummy (the one at the end of J) could be reversed

b1M1: CAO (Activity I only) – if more than one activity stated as being critical then M0

b1A1: Correct reasoning – mention that every/all paths/routes (in the network) contain activity I e.g. 'there is no route that doesn't contain I' scores M1A1. Must mention 'path', 'route' etc. so e.g. 'everything passes through I' would score M1A0 (but 'every route passes through I' is fine for both marks)

c1B1: Correct answer only (12)

c2B1: Correct answer only (C G H I L M)

Question Number	Scheme	Marks
7.(a)	If CD is not in the tree then AD must be as these are the only two arcs incident to D or the weight of CD is greater than the weight of AD	M1
	$2y + x > 3y - 7 \Rightarrow y < x + 7^*$	A1 (2)
(b)	$4x + 1 < 2y + 1 \Rightarrow y > 2x^*$	B1
	$4x + 1 < 8x - 3 \Rightarrow x > 1$	B1
	$4x + 1 < 3y - 7 \Rightarrow 3y > 4x + 8$	B1 (3)
(c)		B1 B1 B1 B1 (4)

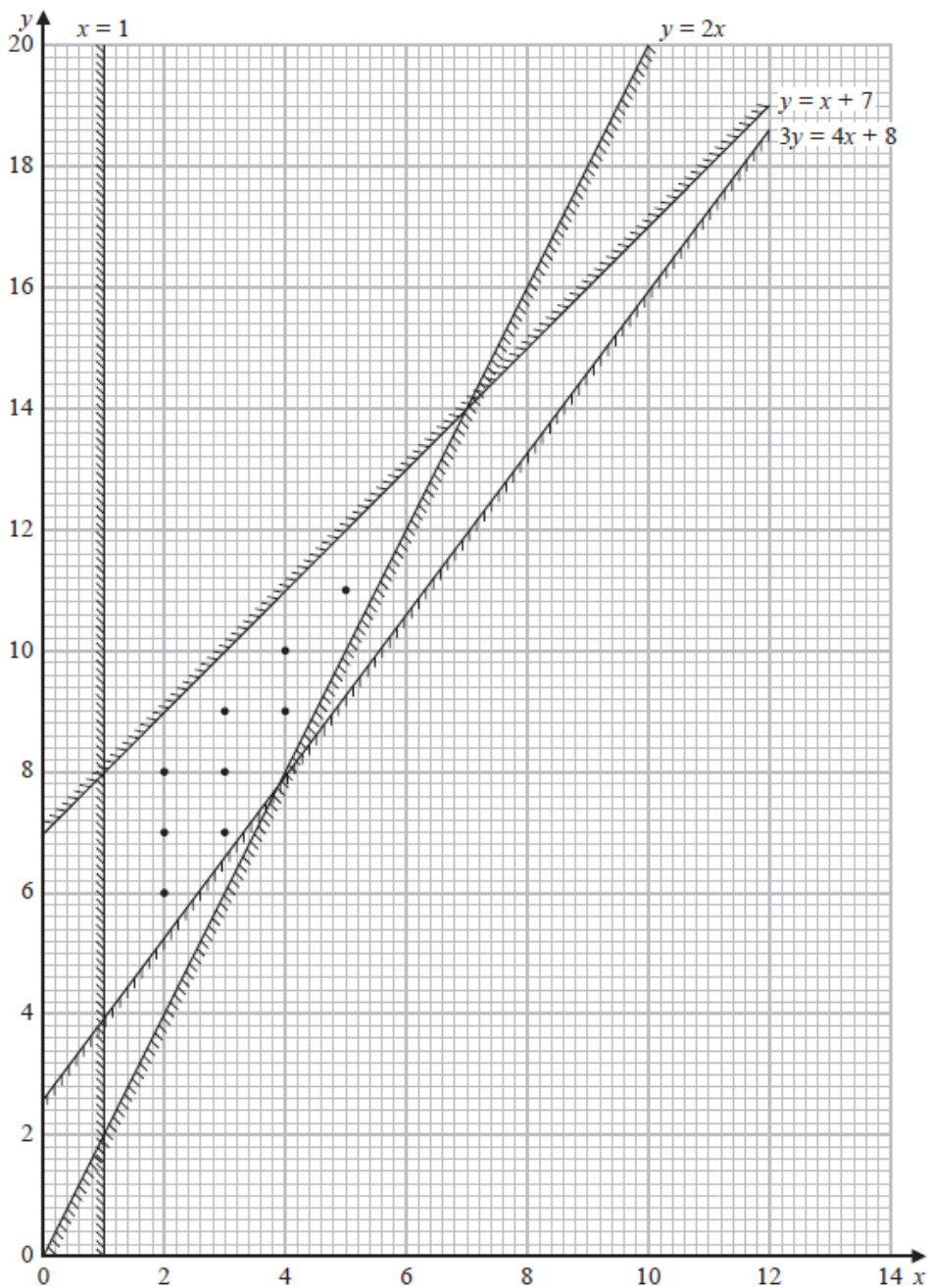

(d)	$(2,6), (2,7), (2,8)$ $(3,7), (3,8), (3,9)$ $(4,9), (4,10)$ $(5,11)$	B1ft B1 (2)
(e)	Arcs in the tree are given as AB, AD, BC, CE, EF and GH – the one remaining arc in the MST is EH (because the weight of arcs EG and FG > weight of arc EH)	M1
	Total weight of the MST is therefore $14x + 5y - 4$	A1
	$14x + 5y - 4 = 73$ and testing integer value points inside FR	M1dep

$x = 3$ and $y = 7$	A1 (4)
	15 marks

Notes for Question 7

a1M1: Explaining that if CD is not in the tree then AD must be e.g. 'the MST must contain D so if CD is not in the tree then AD is'. Must explicitly mention arc AD for this mark, so as a minimum accept, 'AD must be in the MST'

a1A1: Correct reasoning and derivation of the given result ($2y + x > 3y - 7 \Rightarrow y < x + 7$) – as the answer is given we must see at least $2y + x > 3y - 7$ or $3y - 7 < 2y + x$ before the required answer

SC (Special Case) in (a): $2y + x > 3y - 7 \Rightarrow y < x + 7$ without any explanation given (or if explanation is incorrect) can score M1A0

b1B1: CAO – **must see at least** $4x + 1 < 2y + 1$ before the given answer of $y > 2x$ and not just arc $AB < \text{arc } AC$ or $4x < 2y$

b2B1: CAO ($x > 1$) – but allow equivalents, e.g., $x - 1 > 0$, $1 < x$, $4x > 4$, etc. but must be two terms only

b3B1: CAO ($3y > 4x + 8$) – but allow **exact** equivalents e.g. $y > \frac{4}{3}x + \frac{8}{3}$, $4x - 3y < -8$, $4x + 8 - 3y < 0$,

or equivalent but must be three terms only

In (c), the lines can be drawn as either dashed or non-dashed lines (or a combination of the two). The lines must be long enough to define the correct feasible region and pass through one small square of the points stated below:

$y = 2x$ must pass within one small square of (0, 0) and (7, 14)

$y = x + 7$ must pass within one small square of (0, 7) and (7, 14)

$x = 1$ must pass within one small square of (1, 0) and (1, 10)

$3y = 4x + 8$ must pass within one small square of (1, 4) and (7, 12)

c1B1: Any one line correctly drawn (ignore any shading)

c2B1: Any two lines correctly drawn (ignore any shading)

c3B1: Any three lines correctly drawn (ignore any shading)

c4B1: All four lines correctly drawn and shading which implies the correct region (but region need not be labelled)

d1B1ft: At least 4 pairs of integer coordinates correctly stated for points inside their region. This mark is dependent on scoring at least the first two marks in (c) (so must have drawn at least two lines correctly) and the candidate must have drawn exactly four lines. The region must not be infinite but need not necessarily be bounded by all four lines. If the candidate's region does not contain 4 integer coordinates then B0. Note that integer points on the lines that define the boundary of the region are not counted as being inside the region (regardless of if the candidate has strict inequalities or not)

d2B1: All 9 coordinates correct (and no others) – **dependent on all four lines correctly drawn in (c)**

e1M1: States that the remaining arc (in the MST) is one of either EH, EG or FG (and no others). Only one of these three arcs need to be stated for this mark. Allow this mark for either the expression

$(4x + 1) + (3y - 7) + (2y - 2) + (3x) + (x + y) + (6x - 2y + 3) + X$ or the equation

$(4x+1)+(3y-7)+(2y-2)+(3x)+(x+y)+(6x-2y+3)+X=73$ where $X = y+1$ or $2y+4$ or $5x+1$ (or equivalent equations/expressions). Their expression/equation need not be simplified but for reference (if correct) they are $14x+4y-5+X$ and $14x+4y-5+X=73$ (with the expression for X as before). Note that stating $14x+4y-5$ (or equivalent) and then separately stating one of the expressions for X would imply this mark

e2A1: A correct expression for the weight of the MST either simplified ($14x+5y-4$) or not ($((4x+1)+(3y-7)+(2y-2)+(3x)+(x+y)+(6x-2y+3)+(y+1))$). This mark can be implied if a correct equation is seen, e.g. $14x+5y=77$ (or equivalent and again need not be simplified). **If more than one equation or expression seen then they must clearly select the correct expression/equation for this mark** (so stating more than one expression for the weight of the MST is A0)

e1M1dep: This mark is dependent on the first M mark in this part and the first B mark in (d). Setting their linear expression (in x and y) for the weight of the MST equal to 73 and then substituting into this equation at least one integer pair of values of x and y from (d). This mark can also be awarded for substituting at least one integer pair of values of x and y into their linear expression. The correct answers can imply this mark

e1A1: Correct answers only ($x=3$ and $y=7$) from correct working – do not accept any other answers stated as well but accept as a coordinate $(3, 7)$ – **must have drawn the correct four lines in (c) but need not have stated all nine correct coordinates in (d)**. As a minimum for full marks in (e) the candidate must have stated a correct expression (e.g. $14x+5y-4$ or equivalent) or equation (e.g. $14x+5y=77$ or equivalent) before then stating the correct answer

The correct answer with no method or working scores no marks in (e)

Pearson Education Limited. Registered company number 872828
with its registered office at 80 Strand, London, WC2R 0RL, United Kingdom